

# INSTRUCTION SHEET

## Bracket and Crank Pulley Spacer Kit SBC Camaro/Nova Applications 981

We want to help! If you have any comments or difficulty with this product, please contact technical support at



1833 Downs Drive, West Chicago IL 60185

Tech Phone: (630) 849-7754

Sales Phone: (630) 957-4019

Tech Email: tech@powermasterperformance.com

Sales Email: sales@powermasterperformance.com

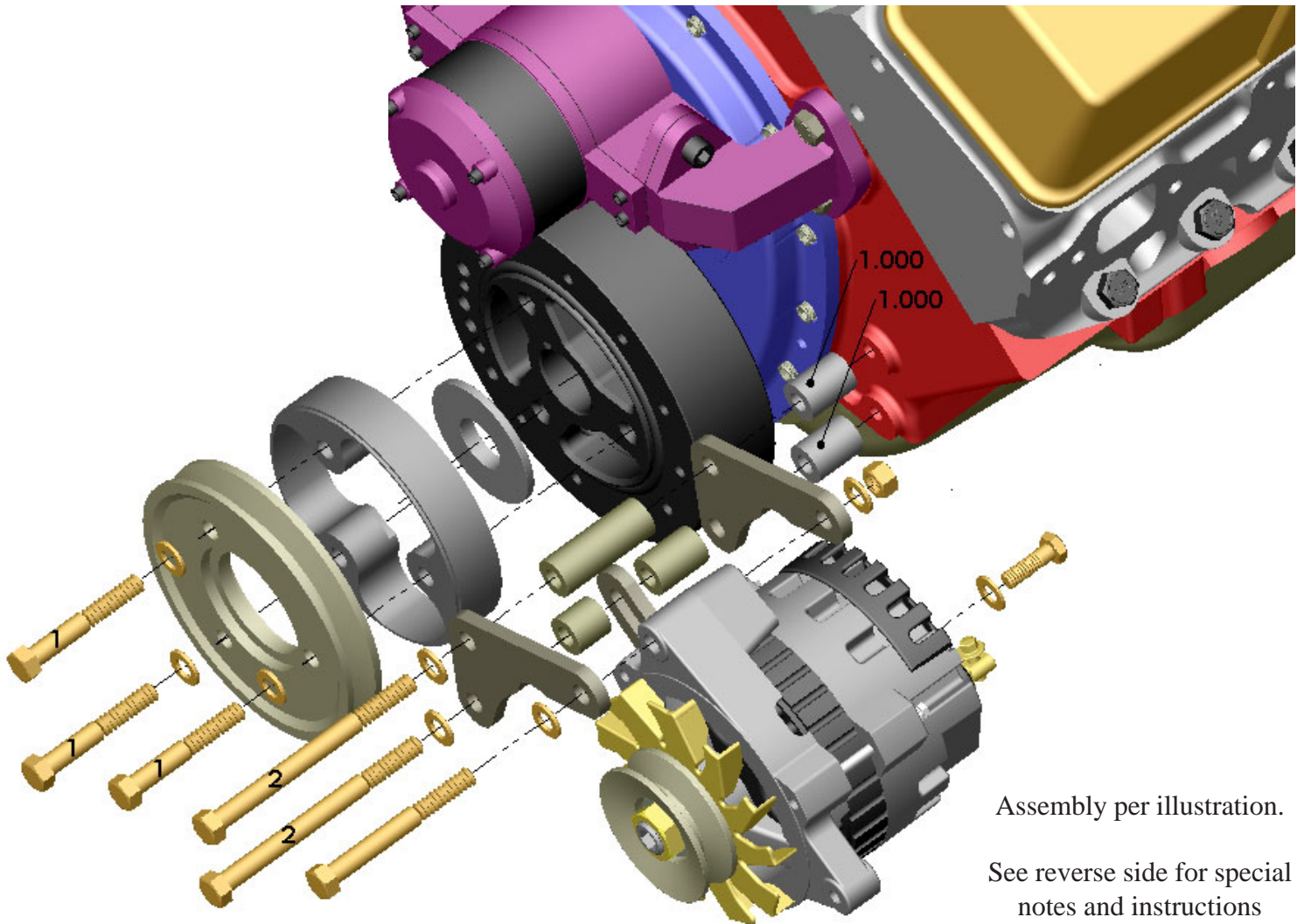
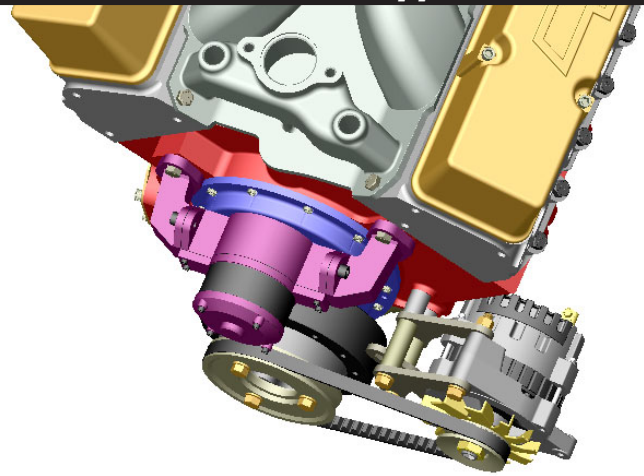

Assembly per illustration.

See reverse side for special notes and instructions

Diagram Ref. #	Part Description	P/N 981 Qty.
	981 three bolt spacer ring, 1.00"	1
1	3/8"-24 X 2 1/2" bolt	3
2	3/8"-16 X 4 1/2" bolt	2
	3/8" ID X 3/4" OD X 1.00" spacer	2

The 981 is designed to work with Powermaster's 100 amp snug mount kits on 1967-1969 small block Camaros and 1968-1972 small block Novas. The 981 shifts the alternator, bracket, and crank pulley forward allowing clearance of the crossmember.

**Requirements for use:**

- Electric water pump

*NOTE: The 981 is not designed to work in conjunction with a crank trigger wheel. Additional bracket spacers and longer bolts are required if adapted.*

**Crank pulley spacer installation**

**1. If installing on an OE balancer**

- Insert the locating bushing (supplied with the crank pulley) into the center notched side of the 981 crank spacer with the bushing's raised ring facing out.
- Place the spacer on the crank balancer with the bushing side facing the balancer. The bushing's raised ring should locate into the center opening on the balancer.

**If installing on a SFI balancer**

- Place the 981 crank spacer on the balancer with the center notched side facing the balancer. The spacer should locate on the step around the outside circumference of the balancer.
2. The crank pulley should then be installed onto the front of the 981 spacer. The pulley should locate on the step around the outside circumference of the spacer. Make certain the side of the pulley with the right angle step is toward the motor and the tapered side is facing away from the motor.
  3. Insert the three 3/8-24 X 2 1/2" bolts (supplied in the 981 kit) through the pulley and spacer and into the balancer. Make certain the mounting holes in the spacer are aligned with the holes in the pulley.

**Alternator bracket spacers installation**

1. Install the 881/882 bracket as shown in the supplied instructions.
2. Add the two 3/4" OD spacers between the bracket's rear triangle and the engine block.
3. The 4 1/2" long mounting bolts supplied with the 981 kit will replace the 3 1/4" long bolts supplied with the 8-881/8-8818 kit.

**NOTE:** The 981 can be used with some other low and snug mount kits to increase alternator clearance of cross members and other obstructions.